

Owner's Manual

Hydrus Commercial Filtration Systems

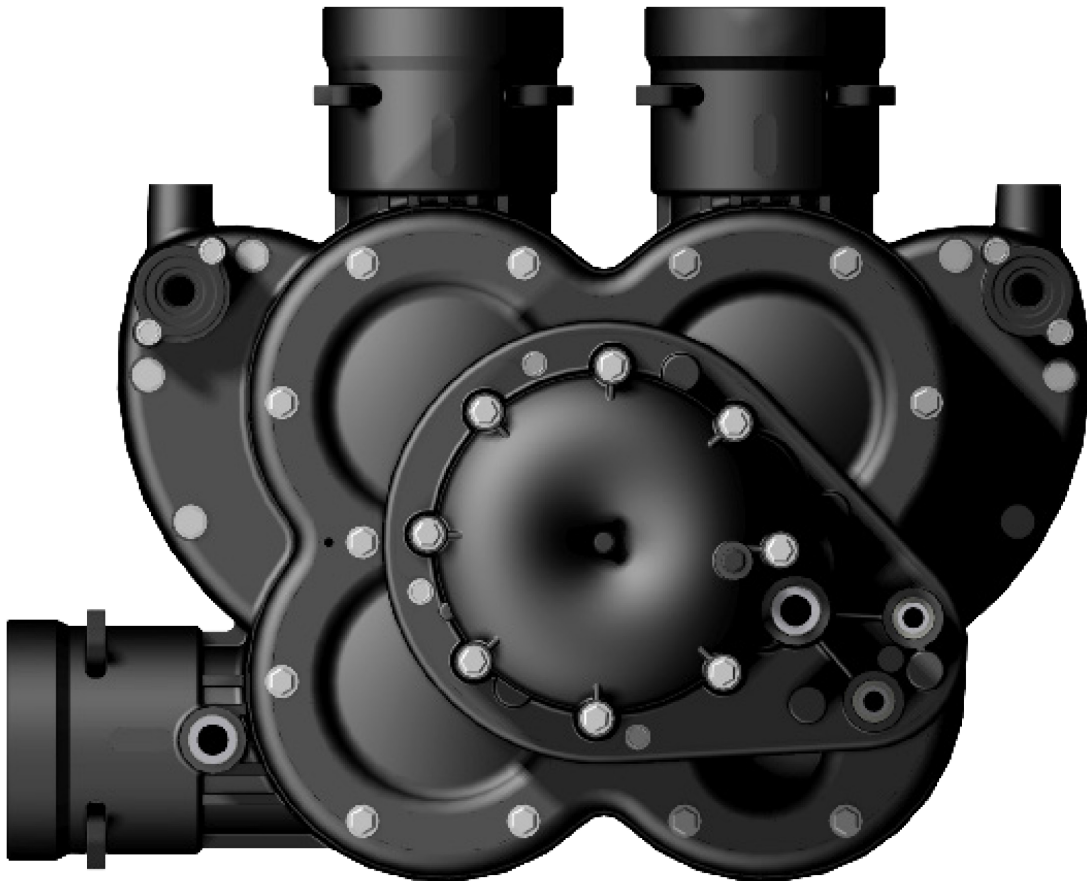

Models:

Carbon:

HF 118cb
HF 121cb
HF 124cb
HF 130cb
HF 136cb

HF 218cb OD
HF 221cb OD
HF 224cb OD
HF 230cb OD
HF 236cb OD

HF 318cb OD
HF 321cb OD
HF 324cb OD
HF 330cb OD
HF 336cb OD

HF 418cb OD
HF 421cb OD
HF 424cb OD
HF 430cb OD
HF 436cb OD

Macrolite[®]:

HF 118m
HF 121m
HF 124m
HF 130m
HF 136m
HF 142m

HF 218m OD
HF 221m OD
HF 224m OD
HF 230m OD
HF 236m OD
HF 242m OD

HF 318m OD
HF 321m OD
HF 324m OD
HF 330m OD
HF 336m OD
HF 342m OD

HF 418m OD
HF 421m OD
HF 424m OD
HF 430m OD
HF 436m OD
HF 442m OD

TABLE OF CONTENTS

THE HYDRUS SERIES COMMERCIAL FILTRATION SYSTEMS

How a Filtration System Works	5
-------------------------------------	---

HYDRUS FILTER DESIGN FEATURES

Automatic Operation	6
Timed.....	6
Volumetric	6
Differential Pressure.....	6
High Flow Rates	6
Low Maintenance Requirements	6
Iron (Ferric Hydroxide) Removal	7

OPERATION

Concepts	7
Level 1-2 Assembly	7
Starting Backwash.....	7
Gear Stack	8
Control Disc	8
Level 3-6 Assembly.....	8
Filter Backwash Sequence	8
Backwash Start	8
Backwash	8
Settle.....	8
Purge.....	9
Start Next	9
Simplex Systems	9
Multiplex Systems	9
Plumbing - Refer to Installation Manual.....	9
Media Tanks.....	9
Diffuser	9
Underbedding	10
Lower Distributor	10
Riser Tube.....	10
Media	10
Macrolite.....	10
Calcite.....	10
Granulated Activated Carbon	10
Smart Start Controller.....	11
Additional External Inputs.....	11

SYSTEM SETUP

Macrolite Filtration Systems	12
Carbon Filtration Systems	12
Calcite Neutralization Systems.....	12
Backwash Flow Control.....	13
Pressure Differential Switch.....	13
Setting the Switch	13
Remote Meter.....	14
Setting the Meter	14

SYSTEM MAINTENANCE

Confirmation of Operation.....	14
Pressure Differential Switches and Remote Meter.....	14
Manual Backwash	15

FILTER SANITIZATION PROCEEDURE

.....	15
-------	----

TROUBLESHOOTING

Excessive Pressure Drop	17
Leaks.....	18
Unfiltered Water to Service	18
Unit Sticks in Backwash or Service Cycle.....	18
Water Running to Drain.....	19

PARTS

Tanks, Tank Fill and Distribution.....	20
Complete Filter Tank Assemblies	20
Tanks.....	20
Distribution.....	21
Complete Valves.....	21
Level 1 / 2	22
Level 3 - 5A.....	23
Level 5B - Base.....	24
Gearing.....	24
Inlet / Outlet Adapters	24
Gears	24
Miscellaneous.....	25
Drain Flow Control	25
Internal Valves.....	25
Base Smart Start Controller.....	26
Complete Smart Start Controllers.....	26
Enclosure.....	26
Electrical.....	26
Miscellaneous	26
Meters - Remote Reset (Smart Start Base)	27
Elite+ Smart Start Controller.....	27
Meters - Remote Reset (Elite+ Smart Start)	27
Pressure Differential Switch, PN 16948	28
Inline Filter, 1/4" Tube, PN 12144	28
Miscellaneous Components	28
Media	28
Installation Kit	29

THE HYDRUS SERIES COMMERCIAL FILTRATION SYSTEMS

Commercial facilities invest in high-quality equipment to carry out the daily tasks of operation. The repair or replacement of equipment that has been damaged by poor quality water can be expensive. KineticoPRO's commercial filtration systems, featuring the Hydrus valve, are used to protect contamination-sensitive equipment. While the systems are excellent platforms for a variety of media requiring periodic backwash, KineticoPRO's standard product line incorporates their use with activated carbon, calcite and Kinetico's proprietary Macrolite® Media.

Activated Carbon is used primarily to remove chlorine, but is also used to remove organic compounds and a number of inorganic compounds¹. Carbon filtration is often used as a pretreatment to processes that are subject to chemical attack by chemicals that are removed by carbon. Some additional benefits of removing these contaminants are improved color, taste and smell of water.

Calcite is used to re-mineralize and neutralize water that has been depleted of minerals and is therefore aggressive, such as permeate from a reverse osmosis treatment system. It is also used to increase the pH of water that's below or at the low end of the National Secondary Drinking Water Regulations, 6.5 - 8.5.

Macrolite is an engineered ceramic media. The advantages of Macrolite are a result of its complex surface structure, chemical resistance and low specific gravity. Macrolite's structure provides for the filtration of particles in the 3-5 micron range. This capacity allows a Macrolite filter to capture ferric hydroxide floc with minimal chemical pretreatment. Note the high surface area of Macrolite as shown in the SEM photographs below.

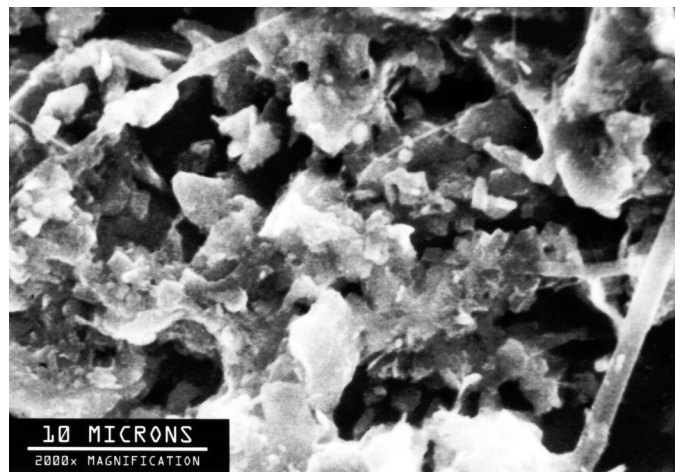
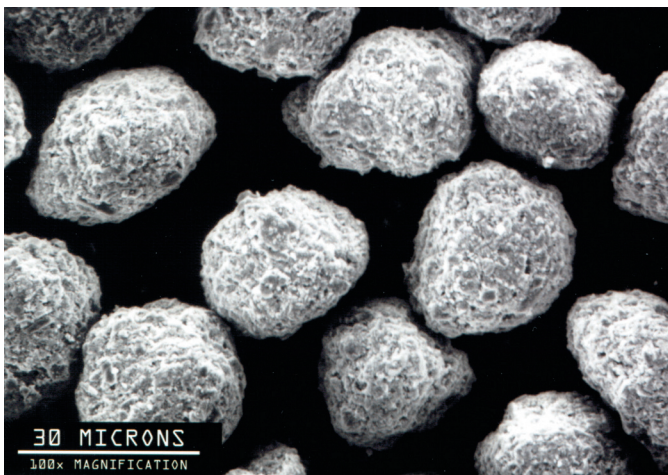

Scanning Electron Microscope (SEM) Photos of Macrolite Media

As a ceramic, Macrolite is extremely durable and chemically inert. This makes it compatible with many types of aggressive processes and imparts an exceptionally long service life. Conservatively, the attrition rate for Macrolite media is estimated to be 1% annually. Most of the media loss is caused through binding to lighter precipitates, which are carried out during the backwash sequence.

Macrolite's physical attributes allow it to be effective at flow rates of up to 10 gpm per square foot of filter area. For proper backwash, a flow rate between 6 to 8 gpm per square foot is required. Even at a low backwash flow rate, Macrolite media is expanded by nearly 100%, allowing more thorough cleaning of the filter bed than old technology filter media. Specific flows are dependent upon water temperature.

Sand is not porous and for that reason is much heavier than Macrolite. It also has irregular shapes. These physical properties require a much higher backwash flow rate to clean it than that required for Macrolite. The sand's surface is very smooth, which also detracts from performance. It is for this reason that the sand particles have only a limited capacity for stopping and holding onto solids suspended in the water. Sand filtration relies upon a composite effect of the whole bed in the form of a filter cake. This fine layer of trapped solids thickens over time. Eventually, the trapped solids become the filter.

¹Water Quality Association, 1989

Other media require particles to be coagulated to larger sizes, allowing them to be trapped on less efficient media such as sand. The physics that elevate Macrolite filtration above sand filtration become obvious when looking at sand under a microscope:

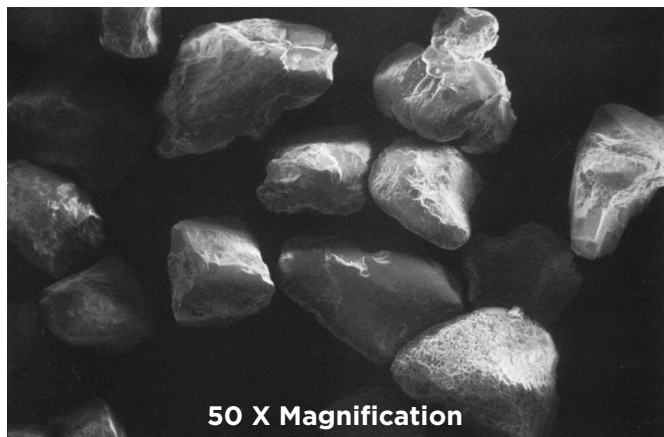

Scanning Electron Microscope (SEM) Photos of Sand

Hydrus commercial filtration systems are also an excellent choice for use with other media, such as adsorptive media used for the removal of arsenic, fluoride and other contaminants.

HOW A FILTRATION SYSTEM WORKS

The concept is simple. Water containing dissolved or suspended contaminants flows through the filter, where the contaminants are absorbed or filtered out. A Hydrus filtration system is also used for neutralization, where aggressive or low pH water flows through the filter to dissolve calcite. Calcite is calcium carbonate (CaCO_3), a mineral common to natural water sources.

These processes have both an operational cycle and a life cycle. The primary portion of the operational cycle is the service cycle. This is where the media does its job providing decontaminated and/or properly conditioned water for distribution. The process continues until the system may begin to show signs of particulate buildup. In the case of filtration, this is the point at which a continuation of service means the leakage of contaminants through the bed. In the case of adsorption and re-mineralization, this is the point at which performance begins to drop off due to pressure drop and/or media classification. To overcome these problems and return a filter to high-quality service, a backwash is required. This is the maintenance portion of the operational cycle.

Carbon and calcite require periodic maintenance. Carbon will eventually saturate as it reaches the end of its useful life cycle, and calcite requires periodic topping off. An advantage of replacing or topping off media contained in Hydrus filtration systems is the Hydrus valve's light weight. Rather than requiring special equipment or unusual strength, Hydrus valves are easy to remove and replace. The traditional integrated commercial filter valves are made of brass, some weighing nearly 50-pounds.

The Hydrus valve integrates an entire valve and plumbing nest into a single, lightweight assembly. This innovative device is engineered to be durable, reliable, accurate, and it comes fully tested. It has earned NSF/ANSI 61 certification¹.

HYDRUS FILTER DESIGN FEATURES

Hydrus filters are available in either a simplex or multiplex configuration. Simplex systems are used in less critical filtration applications, where the by-pass of raw water is not an issue. The multiplex configuration uses filtered water for a backwash sequence and there is no raw water by-pass. Only filtered water leaves a multiplexed Hydrus system. During backwash, the flow rate from a multiplexed Hydrus system may be reduced, because a portion of the filtered water is used for backwash.

¹ NSF is accredited by ANSI, IAS, NELAC and OSHA in the US and the Standard Council of Canada (SCC) in Canada. These accreditations attest to the competency of services provided by NSF and compliance with established national and international standards for third-party certification.

AUTOMATIC OPERATION

Once the Hydrus Filtration System has been installed and properly configured, operation is completely automatic. There are several control methods suitable for efficient filtration, each with a unique effect on the system's operation. A KineticoPRO professional should be consulted to determine which control methodology is best suited for each application. In general, timed and volumetric intervals between backwashes are best suited for adsorptive and neutralizing systems, while a differential pressure control is best suited for Macrolite applications.

Timed

In timed applications, the backwash frequency is projected, set and then later optimized. The setting is conditioned upon the amount of suspended solids in the raw water, what type of particulate pretreatment is present and the nature of the primary treatment media. Backwashing too frequently can damage less robust adsorptive and neutralizing media, while backwashing too infrequently can cause performance to drop due to increased pressure drop through the system or channeling through the media. For calcite or carbon, a weekly backwash is recommended for the baseline.

Volumetric

Volumetric systems are based on throughput. When volume is used to determine when to backwash a Macrolite system, the value will typically range between 7,200 gallons to 14,400 gallons per active square foot of media. For example, a system with a 36-inch diameter vessel has an active media area of 7 ft². This results in a backwash frequency between 50,400 gallons (7 X 7,200) and 100,800 gallons. Variation of backwash frequency is based on solids loading to the filter. As with timed systems, the recommendation is to start with a backwash frequency in the middle of the range, then adjust the frequency based on filter performance.

Differential Pressure

The preferred control method for Macrolite-based filters is to use differential pressure; in this case, the filter optimization can be determined automatically. A differential pressure exceeding 15 psig is a good indication that a bed requires backwashing.

HIGH FLOW RATES

KineticoPRO's Hydrus commercial filtration systems are designed to accommodate the high flows demanded by today's growing business. Despite their compact size, the system provides filtered water when needed, on demand. Flow rates and pressure drops through a system are closely related. As the flow rate increases through a filtration system, the pressure drop increases through the system. Hydrus series commercial filtration systems are designed specifically to minimize pressure drop while maximizing flow rate. The following features are built into every Hydrus commercial filtration system:

- High flow diffusers and distributors - provide minimal pressure loss through system
- Dual layer under-bedding, where beneficial - improves water distribution through system and reduces pressure loss

LOW MAINTENANCE REQUIREMENTS

There are relatively few periodic maintenance requirements of Hydrus commercial filtration systems. Naturally, adsorptive media becomes saturated over time and carbon becomes saturated, each requiring replacement. Neutralization systems require media addition based on their rate of consumption. The state, local or building code may require daily inspection to check for leaks and verify system operation.

On a less frequent basis, the performance of the system can be verified. Initially, this test should be run more often in order to optimize settings.

IRON (FERRIC HYDROXIDE) REMOVAL¹

Any of the above control methods may be used for the removal of ferric hydroxide with a Macrolite filter. Let the following serve as a general guide for filter loading:

Iron (Ferric Hydroxide) Concentration, mg/L	Run Time, hr
<1.0	14-16
1.0 - 2.0	8-10
3-4	<4

OPERATION

This section is provided to instruct on the operation of tanks and controls. KineticoPRO Hydrus Commercial Filtration Systems are an assembly of four major components: the Hydrus valve, the media tank, the media and the Smart Start controller. Together, they provide filtered water efficiently, reliably and continuously. The KineticoPRO professional, when enlisted, has inspected the installation and has made all of the proper adjustments to the system to ensure proper installation, startup and operation.

CONCEPTS

KineticoPRO's Hydrus valve is designed to control commercial, industrial and municipal water treatment equipment. The valve controls all service and backwash functions for a single tank. A separate valve is required for each tank.

Level 1-2 Assembly

The level 1-2 assembly controls the service and backwash cycles for the entire valve.

Starting Backwash

External water flow to the "Start Port" starts the backwash. This hydraulic signal is provided by the Smart Start controller. Alternatively, the water can come from opening a hand valve, a solenoid valve or some similar device. The backwash start requires a flow of about 0.5 gpm. This flow is regulated internal to the valve, so the supply must be able to meet or exceed this flow rate. The length of time to start the cycle is dependent on the length of the overall cycle. Times can range from 2 to 5 minutes.

The backwash start water enters the level 1-2 assembly by means of a 1/4" tubing connection. It spins a turbine, which advances the control disc. As this disc advances, the control valve opens. This allows flow back up to the level 1-2 assembly, passing the regeneration flow control and the nozzle. Once the control valve opens, the external water flow through the 1/4" tubing can stop. The nozzle directs the flow past the regeneration turbine, which drives the gear stack and advances the valve through the backwash cycle.

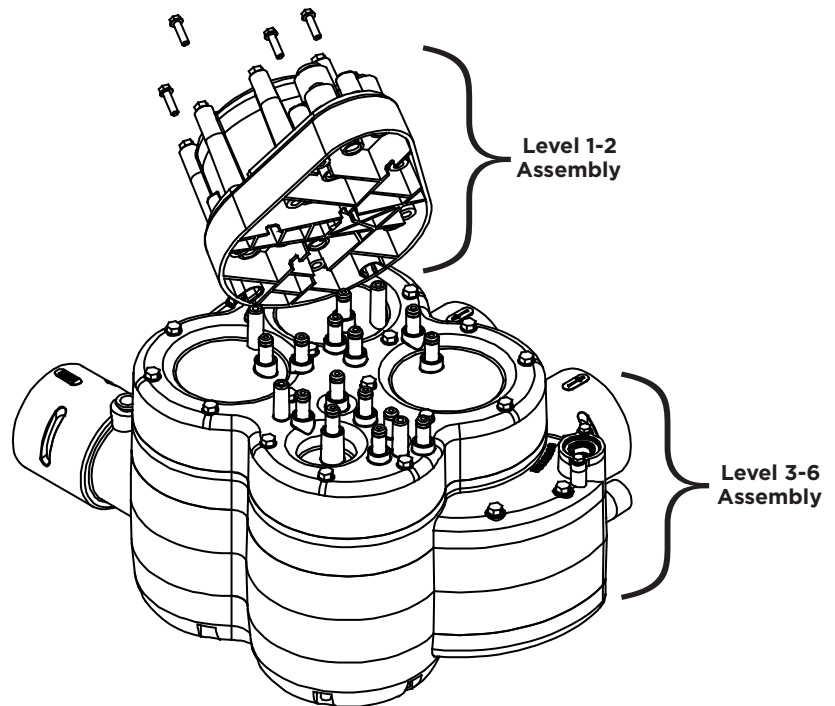

¹ Performance is based upon fully oxidized, suspended iron and flow not to exceed 10 gpm/ft² of media two feet deep. If backwashes are to be initiated based upon time, make certain that the filter is not at risk of being overrun.

Gear Stack

The gear stack controls the length of backwash. Depending on the gearing used, a backwash can be set to durations between 20 minutes and 40 minutes, with 20 being standard. Generally, backwashes more than 20 minutes long are unnecessary. The gear stack drives the regeneration drive pawl, which drives the control disc.

Control Disc

The control disc pressurizes or vents signal holes in the ceramic disc. These ceramic disc holes are connected to servo valves located in the level 3-6 assembly. Level 2 assists in routing the pressure signals from the ceramic disc holes to the proper location on the level 3-6 assembly. The control disc determines what function the valve takes. There is a different control disc for each valve configuration: simplex and multiplex. The control disc is selected based on the tank's function.

Level 3-6 Assembly

The level 3-6 assembly holds the servo valves, valve seats and backwash flow control. Also included within this assembly is the capability of a raw water by-pass. This is located on level 5A. The raw water by-pass is used in simplex systems, allowing untreated water to be diverted to service during a backwash. There are six valves: inlet valve, outlet valve, drain valve, purge valve, control valve and start next valve. The following graphic shows the general scheme and operation of the valve.

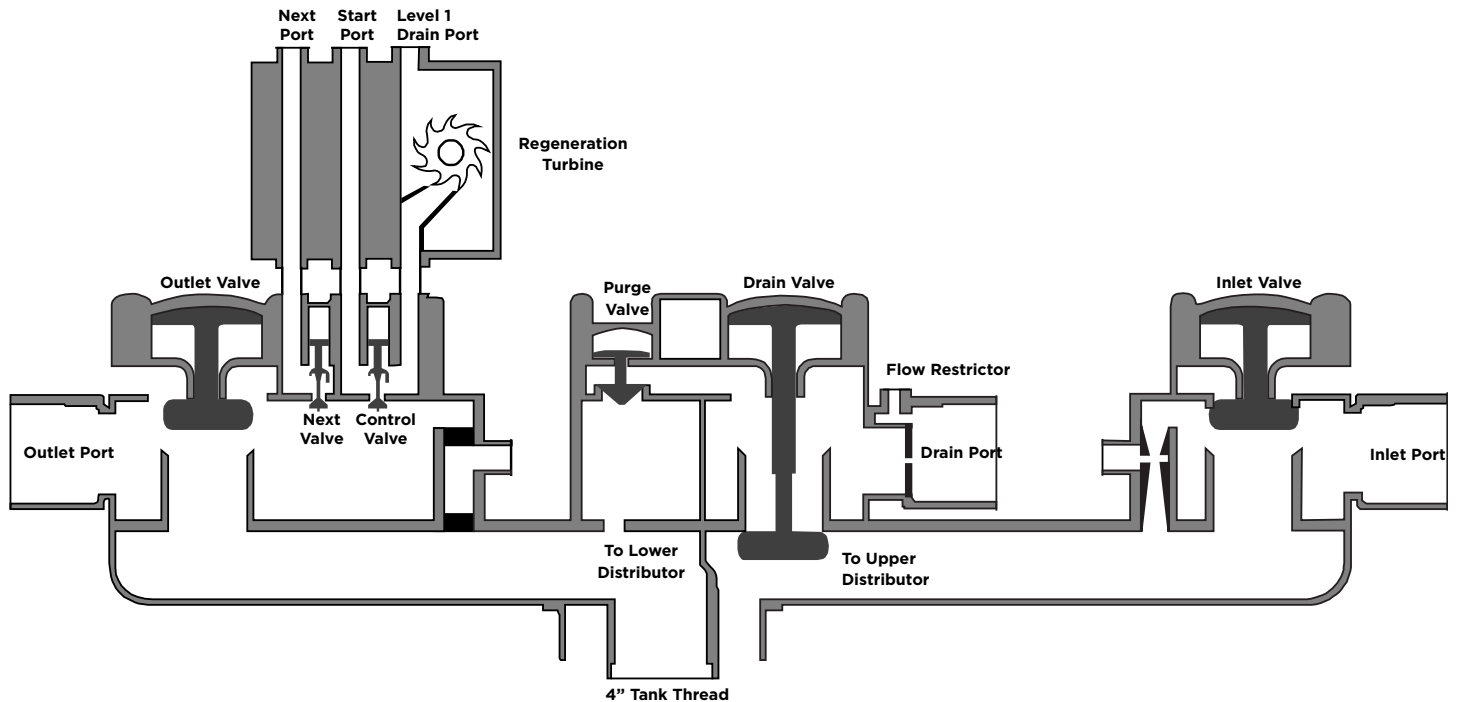

Filter Backwash Sequence

Backwash Start

An external hydraulic signal to the start port causes the turbine to spin. The turbine rotates the gear stack, which moves the control disc. After advancing the control disc four teeth, the control valve opens, providing flow to the turbine for the entire filter backwash sequence. This flow goes to drain at a nominal rate of 0.5 gpm.

Backwash

After the control valve opens, the control disc moves internal valves to initiate the backwash step. In the case of simplex units, the inlet valve closes, diverting water through the by-pass to the outlet valve. In multiplex systems, the water is not diverted and no unfiltered water goes out to the process. The outlet valve is open, allowing the use of filtered water for backwash in multiplex systems. A filter is backwashed to remove accumulated solids and to reclassify the media.

Settle

During the settle step, the drain valve is closed. The control flow continues to rotate the turbine, which advances the control disc through the rest of the step. No water flows through the tank, allowing media to reclassify in a natural condition. Settling takes about two minutes and is followed by the purge cycle.

Purge

During the purge step, the inlet and outlet valves are open on simplex systems. On multiplex systems, the outlet is closed. This step allows the bed to gently compact before going into a full service mode. The outlet valve is closed, but allows water from online tank(s) to flow through the control valve. This keeps the turbine spinning and automates the backwash cycle.

Start Next

Before the control flow shuts down, the last step is to provide a start next hydraulic signal to the next Hydrus valve in the system. This might be a carbon filter, which follows the filter that was just backwashed. The signal is sent when the start next valve is opened. During this step, the Hydrus valve is processing filtered water to service.

SIMPLEX SYSTEMS

The simplex configuration is fairly straightforward in its operation. As a single tank, the backwash occurs without affecting any other tanks or sub-systems that may be present. Raw water is by-passed around the treatment system during a backwash. Raw, untreated water is also used for the backwash process. Once the hydraulic signal is received by the valve, the backwash sequence proceeds completely automatically through backwash, settle and purge cycles.

MULTIPLEX SYSTEMS

The multiplex systems' configuration differs from simplex systems primarily during backwash. In general, multiplex systems are used for more critical applications, where a continuous supply of filtered water are required, where high flow is required or where filtered water specifications require.

During service, all of the tanks are operating at equal flow rates in parallel. The softening media removes suspended solids, neutralizes, or adsorbs and eventually approaches capacity or becomes loaded with suspended solids. Taking several factors into account, a backwash can be initiated based upon time in service, differential pressure or the volume of processed water. For this, the unit may be equipped with a flow meter or a differential pressure switch. To provide the most efficient, productive backwash, Hydrus multiplex systems use filtered water for backwashing.

PLUMBING - REFER TO INSTALLATION MANUAL

It's important that the Hydrus system is plumbed with isolation and by-pass valves and approved materials using approved methods. It's implicit that the system is installed with proper fittings, is isolated and has expansion capabilities. Plumbing specification is outside the scope of this manual and subject to local code.

MEDIA TANKS

The media tanks are made up of several components: the tank itself, upper diffuser, media, underbedding, lower distributor and riser. The raw water flows into the valve and through the upper diffuser at the top of the tank just beneath the valve. It flows through the media where the filtration, neutralization or adsorption process takes place. The water is now "filtered." On the bottom of the media bed, there are up to two different grades of underbedding. Smaller systems require only one layer. The water flows through the underbedding and into the distributors. Lastly, the water flows up the riser tube and out the valve to service.

DIFFUSER

The diffuser presents channeling of the inlet stream into the top of the media bed. A plastic molded diffuser is attached to the bottom of the Hydrus valve.

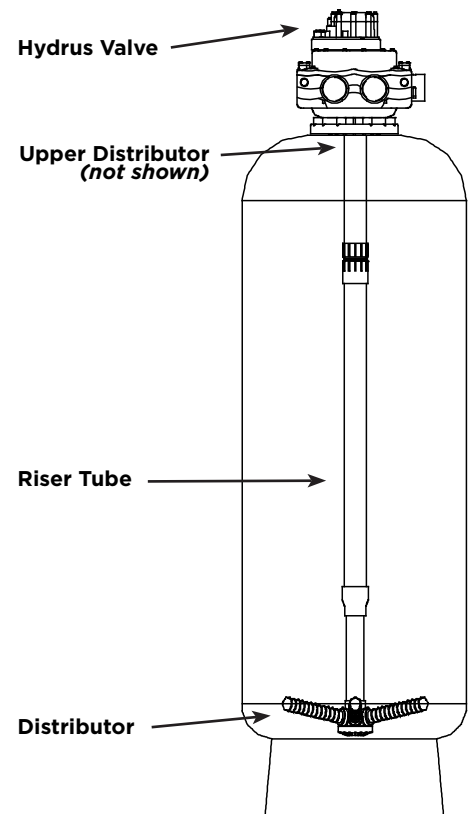

UNDERBEDDING

In order to ensure proper distribution, minimal pressure drop and to protect the distributors from fouling, two different grades of underbedding may be used. Only fine grade gravel is required for small tanks.

LOWER DISTRIBUTOR

The lower distributors have a hub and slotted lateral design. This provides flow distribution through the bed. The high surface area of the laterals minimizes pressure loss through the system. The polypropylene construction of the distributor assembly gives it excellent durability.

RISER TUBE

A riser tube is used to connect the lower distributor to the control valve. The riser tube is 2.0" in diameter and cut to length, depending upon the tank size.

MEDIA

As standard media, KineticoPRO uses Macrolite for filtration, calcite for neutralization and granular, activated carbon for de-chlorination and other purposes.

Macrolite

Macrolite is an engineered ceramic media used for standard particulate filtration with several advantages over traditional sand filtration.

Benefits of Macrolite over Sand

- Reduced backwash flow rates - 8 to 10 gpm/ft² versus 15-22 gpm/ft² for sand
- Reduced backwash volume - 180 gal/ft² versus 370 gal/ft² for sand
- Increased service flow rates - 8 to 10 gpm/ft² versus 2-6 gpm/ft² for sand

Calcite

Calcite is a naturally-occurring calcium carbonate media. One of the advantages of calcite is its self-limiting property. When properly applied, it corrects pH only enough to reach a non-corrosive equilibrium. Upon contact with calcite, acidic waters slowly dissolve the calcium carbonate to raise the pH, which reduces the potential leaching of copper and other metals found in typical plumbing systems. Periodic backwashing will prevent packing, reclassify the bed and maintain high service rates. Depending on pH, water chemistry and service flow, the calcite bed will have to be periodically replenished as the calcite is depleted¹.

As calcite neutralizes the water, it will increase hardness, and a softener may need to be added after the filter. This should be taken into account for low pH applications.

Granulated Activated Carbon

Carbon is used for the removal of chlorine and dissolved organic compounds from potable water that can cause taste and odor problems and health issues. Activation is carefully controlled to produce an exceptionally high internal surface area with optimum pore size for effective adsorption of a broad range of high and low molecular weight organic contaminants².

Activated carbon requires only periodic backwashing to eliminate accumulated suspended matter and re-grade the filter bed. When the filter bed loses the capacity for chlorine, the bed must be replaced. If the unit is used in conjunction with a chlorine feed system for the removal of oxidized iron, the unit should be set to backwash one or two times per week of operation.

¹ Adapted from product bulletin for calcite, Clack Corporation, January, 2004.

² Adapted from product bulletin for GW 12x40 carbon, Calgon Carbon Corporation, 2004.

SMART START CONTROLLER

KineticoPRO's Smart Start control box allows a versatile system set-up. One controller can start the same sequential backwash of multiple valves, regardless of their application. Multiple systems can be initiated with same signal. For systems using multiple valves that require independent control, one Base Smart Start controller is required for each Hydrus valve or one Elite+ Smart Start controller can control up to two independent Hydrus valves.

The Smart Start controller has three basic operating modes.

Day Mode: Time/Day - 7-day selection. Day Mode initiates a backwash based on the day of the week and the time of day. A time of day to backwash can be programmed on the board. Then, the days of the week to regenerate are programmed.

Countdown Timer: 0-99 hours between backwashes. Countdown Timer Mode initiates a backwash based on the time elapsed since the last backwash.

Input Mode: Starts a backwash when a signal is received from an external flow meter or differential pressure switch. This signal can start the backwash immediately, or it can be delayed.

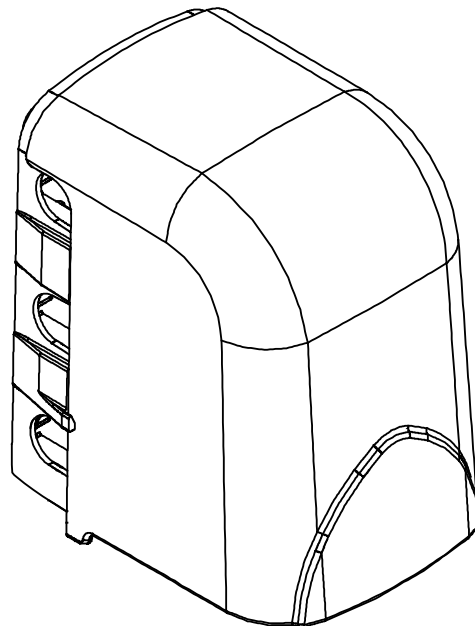

Additional External Inputs:

The timer board has two additional external inputs that can be used to start a backwash sequence. These inputs must be a dry contact, for a minimum of five seconds for flow and 15-minutes for differential pressure to initiate the sequence. The inputs can be tied into either operating mode, thus extending the flexibility of any system design.

- Volume: dry contact from meter (meter not provided with Smart Start)
- Differential Pressure: dry contact from pressure sensor (sensor not provided with Smart Start)

SYSTEM SETUP

The following guidelines must be followed:

- The system and its installation must comply with all plumbing codes and regulations
- The system is to be installed indoors on a level, solid surface
- The system is not intended to be used for treating water that is microbiologically unsafe or of unknown quality without disinfection before or after the system
- The procedure for sanitizing the system found on page 15 must be followed after installation and service that may cause contamination

Failure to follow the instructions in this manual or to follow proper installation procedures may void the warranty, cause injury, cause the system to operate improperly or not at all and/or cause damage to the system. Compliance must also be achieved if modifying the original installation.

MACROLITE FILTRATION SYSTEMS

The following chart is a quick reference to typical tank fills and flow rates of Macrolite Filtration Systems:

	18 x 65	21 x 62	24 x 65	30 x 72	36 x 72	42 x 72
Tank Volume	8.3 ft ³	11 ft ³	13.4 ft ³	25 ft ³	35.3 ft ³	46.1 ft ³
Garnet Underbedding Weight	150 lb	150 lb	250 lb	400 lb	500 lb	750 lb
Macrolite Volume	2.5 ft ³	3.5 ft ³	5 ft ³	8 ft ³	12 ft ³	16 ft ³
Flow Rate (10 gpm/ft ²)	17 gpm	24 gpm	31 gpm	49 gpm	70 gpm	96 gpm
Backwash Flow Rate (8 gpm/ft ²)	14 gpm	19 gpm	25 gpm	39 gpm	57 gpm	77 gpm
Backwash Frequency	15 psid	15 psid	15 psid	15 psid	15 psid	15 psid

CARBON FILTRATION SYSTEMS

The following chart is a quick reference to typical tank fills and flow rates of Carbon Filtration Systems:

	18 x 65	21 x 62	24 x 65	30 x 72	36 x 72
Tank Volume	8.3 ft ³	11 ft ³	13.4 ft ³	25 ft ³	35.3 ft ³
Fine Gravel	1 ft ³	1 ft ³	0.5 ft ³	2 ft ³	2 ft ³
Coarse Gravel	n/a	n/a	1 ft ³	1 ft ³	2 ft ³
Carbon Volume	3 ft ³	4 ft ³	6 ft ³	10 ft ³	14 ft ³
Flow Rate ¹ (8 gpm/ft ²)	14 gpm	19 gpm	25 gpm	39 gpm	57 gpm
Backwash Flow Rate (10 gpm/ft ²)	17 gpm	24 gpm	31 gpm	49 gpm	70 gpm
Backwash Frequency ²	Weekly	Weekly	Weekly	Weekly	Weekly

Kineticopro uses a robust activated carbon with broad applications. Its most prevalent use is in the removal of chlorine, which is used for disinfection. It is also an excellent choice for the removal of organic carbons and other contaminants.

While the removal of chlorine is predictable, the removal of organic carbons and other contaminants is not. There can be wide variance in the adsorptive capabilities of carbon to remove MTBE and organic contaminants, due to the effects of differing water chemistries. The Hydrus Carbon Filtration System lends itself very well to this application. The table below provides a general sizing guideline. If the system proves to be insufficient, it's easily expanded by simply adding an additional tank.

	18 x 65	21 x 62	24 x 65	30 x 72	36 x 72	EBCT
Chlorine	4-15 gpm	6-20 gpm	9-26 gpm	15-40 gpm	21-57 gpm	1.5-5 minutes
Organic Carbons	2-4 gpm	3-6 gpm	4-9 gpm	7-15 gpm	10-21 gpm	5-10 minutes
MTBE	1-2 gpm	2-3 gpm	3-4 gpm	5-7 gpm	7-10 gpm	10-15 minutes

CALCITE NEUTRALIZATION SYSTEMS

The following chart is a quick reference to typical tank fills and flow rates of Calcite Filtration Systems:

	18 x 65	21 x 62	24 x 65	30 x 72	36 x 72
Tank Volume	8.3 ft ³	11 ft ³	13.4 ft ³	25 ft ³	35.3 ft ³
Fine Gravel	1 ft ³	1 ft ³	1 ft ³	2 ft ³	2 ft ³
Coarse Gravel	n/a	n/a	1 ft ³	1 ft ³	2 ft ³
Calcite Volume	3.5 ft ³	5 ft ³	6.5 ft ³	10 ft ³	14 ft ³
Flow Rate ¹ (6 gpm/ft ²)	11 gpm	15 gpm	19 gpm	39 gpm	43 gpm
Backwash Flow Rate (10 gpm/ft ²)	17 gpm	24 gpm	31 gpm	49 gpm	70 gpm
Backwash Frequency ²	Weekly	Weekly	Weekly	Weekly	Weekly

1 At 8 gpm/ft², this is the maximum recommended flow rate for chlorine removal from a typical city-water supply, ≤ 0.5 mg/L. Absorption of other commonly removed contaminants is shown on the following page.

2 More frequent backwashing may be required. This is dependent upon the amount of solids loading to the filter.

BACKWASH FLOW CONTROL

For all control valves, one backwash flow control per valve is required. Supplied with each valve is a backwash flow plate. Based on the desired backwash flow rate, this plate is drilled out to provide this flow.

Target Flow Rate (gpm)	Drill Size (inches) Based on Inlet Pressure		
	30-45 psi	45-60 psi	>60 psi
8	0.250 (1/4)	0.234 (15/64)	0.218 (7/32)
10	0.281 (9/32)	0.265 (17/64)	0.234 (15/64)
15	0.375 (3/8)	0.328 (21/64)	0.296 (19/64)
20	0.406 (13/32)	0.390 (25/64)	0.359 (23/64)
30	0.515 (33/64)	0.453 (29/64)	0.437 (7/16)
40	0.609 (39/64)	0.531 (17/32)	0.468 (15/32)
55	0.718 (23/32)	0.625 (5/8)	0.546 (35/64)
75	0.750 (3/4)	0.734 (47/64)	0.718 (23/32)

Note: Pressure at 60° F (15.6°C) water temperature.

PRESSURE DIFFERENTIAL SWITCH

A pressure differential switch monitors the pressure difference between the inlet and the outlet streams and trips when it reaches a preset differential pressure. It is designed with two separate, opposing sensors which are connected to actuate a switch. The actuation produces a dry contact, which is sensed by the Smart Start controller. The Smart Start controller is thus triggered to produce the hydraulic signal required to initiate the backwash sequence.

The following warnings are stated by the manufacturer:

- To avoid damaging unit, pressure and maximum temperature limits stated in literature and on nameplates must never be exceeded, even by surges in the system. Operation of the unit up to maximum pressure or temperature is acceptable on a limited basis, but continuous operation must be restricted to the designated adjustable range. Excessive cycling at maximum pressure or temperature limits could reduce sensor life.
- Install unit where shock, vibration and ambient temperature fluctuations will not damage unit or affect operation. When applicable, orient unit so that moisture does not enter the enclosure via the electrical connection. When appropriate, this entry point should be sealed to prevent moisture entry.

Setting the Switch

The switch is not preset, but arrives near the midpoint of its operational limit of 25 psid. This value is normally between 10 and 15 psid. This means the switch will trip if the influent water pressure is 80 psig and the effluent water pressure is between 65 and 70 psig. A 1/2 turn on the adjustment set screw will change the pressure for differential by approximately 5 psi. Turn the screw clockwise to decrease the psid and counterclockwise to increase it. The Smart Start controller requires a closed contact; therefore, connection to the controller from the pressure differential switch must be from the Normally Open (NO) and Common (C) contacts.

Different media exhibit different clean bed pressure drops, as do differing tank/plumbing combinations. Media performance of Macrolite systems is directly dependent upon differential pressure, so triggering a backwash sequence at the correct pressure differential is essential. The system can be optimized, but a nominal pressure differential of 15 psid is practical. This means the pressure differential switch is set for 15 psid, where the clean-bed differential pressure is 5 psid. Individual beds may vary. Theoretical values calculated using empirically derived C_v values for Macrolite predict a differential pressure of approximately 1.3 psid.

Carbon and calcite systems do not require as careful control of differential pressure for proper function. They do not usually exhibit differential pressure like classic filtration systems. That is why timed service between backwashes is sufficient for most applications.

1 At 6 gpm/ft², this is the maximum recommended flow rate for neutralization. At this flow rate, complete neutralization may not occur.

2 More frequent backwashing may be required. This is dependent upon the amount of solids loading to the filter.

REMOTE METER

The remote meter monitors the soft water service flow at the control outlet with the meter impeller being the only in-stream moving part. As the turbine turns, feedback is sent to the controller that will trigger regeneration immediately or on a delayed basis depending on its programming.

KineticoPRO offers two Smart Start controller models:

- Base Smart Start: uses mechanical actuation to measure water usage and initiate regeneration. KineticoPRO modifies the mechanical meter from its original configuration to allow it to interface with the Base Smart Start controller.
- Elite+ Smart Start: advanced digital controller programmable through USB and WiFi. Uses Hall effect meter to send digital pulses to the controller and trigger regeneration. Depending on flow meter, pulses per gallon will vary and can be adjusted through programming.

SYSTEM MAINTENANCE

KineticoPRO has engineered the Hydrus system to provide quality water without requiring extensive maintenance. Minor routine maintenance is recommended to keep the softener working properly.

No special tools are required for system repairs or maintenance. If the system is completely cut off from power, whether hydraulic or electrical, the system does not require resetting. It picks up where it left off. These are some of the many benefits built into all Hydrus Filtration Systems to ensure trouble-free ownership.

CONFIRMATION OF OPERATION

Depending upon how critical the treatment is to its process or distribution, periodic verification of its operation should be carried out.

- Macrolite:** Verify that the water leaving the system is clear, has low suspended solids and its written specification of the target contaminant. A turbidimeter may be used to check for clarity. Laboratory testing may be required for contaminants such as arsenic, iron and/or manganese. Monitor the level of the media, and periodically top it off.
- Carbon:** Verify that the water leaving the system is free of chlorine. Otherwise, ensure that target contaminants are being removed by the carbon. Monitor these levels to determine the media exhaustion, and periodically replace it.
- Calcite:** Verify that the water leaving the system is neutral by checking the pH and conductivity. Monitor the level of the media and periodically top it off.

PRESSURE DIFFERENTIAL SWITCHES AND REMOTE METER

As with any control devices, a certain amount of care is required. This involves periodic calibration and verification of parameters set. Occasionally, the devices may require removal and cleaning, depending upon the environment they are exposed to. A backup unit is necessary for applications where damage to a primary unit could shut down the process.

In the verification of differential pressure switches, gauges should be used at the inlet and outlet side of the media tank or system.

A remote meter is installed to measure the volume of processed water. Once the set volume is reached, a signal is interpreted by the Smart Start controller, which in turn sends a hydraulic signal to the lead tank to initiate a regeneration. A remote meter can be used with both simplex and multiplex systems. For multiplex systems, the meter is located on the combined system outlet.

Manual Backwash

At some point, a manual backwash may be required. An automatic backwash will eventually occur, but unfiltered water may overrun the filter and enter the distribution system until a backwash occurs.

There are several ways to force the Hydrus valve to backwash:

1. If using a Base Smart Start controller (refer to its specific owner's manual):
 - a. Advance the Remote Meter
 - b. A backwash can also be forced by following the procedure described in controller manual. The procedure manually opens the solenoid valve, which in turn directs a flow of water to the Start Port of the Hydrus Valve.
2. If using the Elite+ Smart Start controller:
Press the manual backwash button for 5 seconds. It is located underneath the control box.
3. Directly on the Hydrus valve with any controller: Manually advance Level 1-2 of the Hydrus valve, as shown below and described:

To manually backwash the system, use a 1/4" nut driver to turn the small, hex-shaped "Override Actuator." Slowly turn counter-clockwise until the actuator has advanced the "Indicator" arrow to the "BACKWASH" position, about 10°. At this point, the flow of water will be audible. This indicates a successful backwash initiation has occurred. If water flow is not heard, contact a KineticoPRO professional.

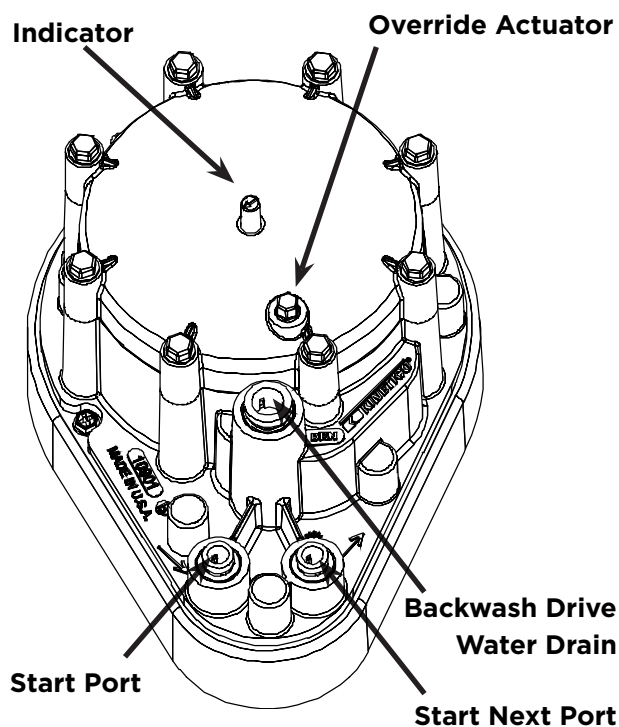

FILTER SANITIZATION PROCEDURE¹

The following is taken from the AWWA Standard for "Disinfection of Water Treatment Plants". Only those parts deemed relevant to the Hydrus system are summarized. It's provided as a general guide of scope and is not intended to be a substitute for a licensed, experienced professional.

This standard covers facility preparation, application of chlorine to the interior surfaces of water treatment units, and sampling and testing for the presence of coliform bacteria. All new treatment facilities to be disinfected in accordance with this standard must be chlorinated before they are placed in service.

All treatment facilities taken out of service for inspection, repairing, painting, cleaning, or other activity that might lead to contamination of water should be disinfected before they are returned to service. All units that are downstream from the first point of application of disinfectant in the treatment process should be disinfected in accordance with this standard. Typically, these units are filter basins or vessels, filter media, clearwells, pump suction wells, and all associated piping and appurtenances.

1. Prior to the replacement of any filter material, the filter basin or vessel itself shall be properly cleaned.
2. Subsequent to cleaning of the filter basin or vessel, filter media must be placed in the basin or vessel with all reasonable precautions to maintain cleanliness..
3. Following placement, the filter media must be backwashed and prepared for service.
4. After all other work is completed, and before the filter is placed in service, the entire filter basin or vessel up to the maximum water level must be disinfected by chlorination.
 - a. This can be accomplished preferably by injecting sufficient chlorine into the backwash water to produce a free chlorine residual of at least 25 mg/L throughout the filter.
5. When this is accomplished, the chlorinated water must be allowed to stand in the filter for at least 12-hours. At the end of the 12-hours contact time, the chlorinated water must be tested to determine the free residual.

¹ Adapted from ANSI/AWWA C653-87 (First Edition). This has been replaced by ANSI/AWWA C653-03 AWWA Standard for "Disinfection of Water Treatment Plants" American Water Works Association, June 1, 2003.

- a. If the free residual is less than 15 mg/L, the chlorination process must be repeated.
- b. Sufficient tests should be made both from the top and the bottom of the unit (and at intermediate points if feasible) to ensure that the residual readings measure the lowest chlorine level existing in the unit at the end of the 12-hour period.
- 6. After the chlorine retention period, if satisfactory chlorine residuals are obtained, the filter must be run to waste or backwashed thoroughly to remove the highly chlorinated water.
 - a. If there is any question that the chlorinated discharge will cause damage to the environment, a reducing agent must be applied to the water to neutralize the residual chlorine.
 - b. Federal, state or local environment regulations may require special provisions or permits prior to disposal of highly chlorinated water.
- 7. After the chlorination procedure is completed, and before the treatment unit or facility is placed in service, at a minimum, duplicate samples must be taken from the unit or facility not less than 30 minutes apart and must be tested for the presence of coliform.

Check with a local sewer department for conditions regarding the disposal of heavily chlorinated water to a sanitary sewer. Chlorine residual of water being disposed will be neutralized by treating with one of the chemicals.¹

Residual Chlorine, mg/L	Sulfur Dioxide (SO ₂), lb	Sodium Bisulfite (NaHSO ₃), lb	Sodium Sulfite (Na ₂ SO ₃), lb	Sodium Thiosulfate Pentahydrate (Na ₂ S ₂ O ₃ · 5 H ₂ O), lb
1	0.8	1.2	1.4	1.2
2	1.7	2.5	2.9	2.4
10	8.3	12.5	14.6	12.0
50	41.7	62.6	73.0	60.0

Table of Reducing Chemicals (neutralization/100,000 gallons of waste)

TROUBLESHOOTING

KineticoPRO has identified five problems familiar to filtering systems. This troubleshooting guide is intended to serve as a useful diagnostic tool in solving more common, easy to determine problems. If the problem is not shown below, a call to the local KineticoPRO professional should be helpful. Beginning with “Excessive Pressure Drop,” possible reasons for the complaint and the corresponding solutions are given.

EXCESSIVE PRESSURE DROP.....17

- External input to Smart Start controller not working.....17
- The unit will not go into automatic backwash17
- The upper diffuser and/or lower distributor are plugged.....17
- Insufficient backwash.....17

LEAKS18

- Water leaks from any of the assembly levels.....18

UNFILTERED WATER TO SERVICE18

- The by-pass is open18
- Raw water change.....18
- Diffuser tube O-ring.....18
- Fouled media.....18
- Water feed pressure is too high (125 psi maximum).....18

UNIT STICKS IN BACKWASH OR SERVICE CYCLE19

- Backwash19
- Service.....19

WATER RUNNING TO DRAIN19

- The balance piston O-ring is not seated properly19
- Bad control disc19
- Valve not sealing, drain purge control, stem or piston quad rings not sealing19
- Low water pressure.....19

¹ The above are estimated neutralization dosages to be used as a general guide.

EXCESSIVE PRESSURE DROP

Problem	Reason	Solution
1. External input to Smart Start controller not working	❑ Water meter not producing a dry-contact signal.	■ Replace meter.
	❑ Differential switch is not producing a dry-contact signal.	■ Replace switch.
	❑ Hydraulic signal being interrupted from Smart Start Controller.	■ Troubleshoot Smart Start Controller.
	❑ Minimum flow rate for 2" meter is 3 gpm and 7 gpm for a 3" meter.	■ Identify cause of low flow rate. Reduce capacity set-point to compensate for non-metered low flow.
2. The unit will not go into automatic backwash	❑ Level 1 drain blocked.	■ Unblock and/or re-run.
	❑ Meter or timer not properly programmed.	■ See Econominder Remote Reset Meters: 2750RM, 2850RM, 3100RM & 3900RM; Service Manual from Fleck.
	❑ Regen drive pawl defective.	■ Replace pawl if the indicator does not move during backwash or manual advance.
	❑ Actuated solenoid not producing water. Base Smart Start battery dead.	■ Repair or replace solenoid. Replace battery.
	❑ Start solenoid inlet screen plugged.	■ Clean, repair or replace solenoid or screen.
3. The upper diffuser and/or lower distributors are plugged	❑ Foreign matter from the input lines is accumulating in the distributor and/or diffuser.	■ Clean the diffuser and/or distributor. Add a prefilter to eliminate the foreign matter before it enters the unit.
4. Insufficient backwash	❑ Outlet pressure below 30 psi.	■ Increase pressure to system if this condition exists on a clean bed.
	❑ Low backwash flow rate.	■ Place unit in backwash and measure drain flow rate and outlet pressure. Clean backwash flow control. Increase backwash flow control orifice if needed.
	❑ Backwash too short.	■ Examine backwash water at the end of backwash. If the backwash water is still dirty, increase the backwash flow control orifice, or re-gear for a longer backwash. (WARNING! Increasing the backwash flow rate too much causes media loss.)
	❑ Media fouled.	■ Obtain a media core sample. Inspect for fouling. Clean or replace the media as needed.
	❑ Drain line is clogged.	■ Clear any obstructions. Make sure drain line flows smoothly and unrestricted.
	❑ Drain is extremely long or placed higher than 8 feet above the unit.	■ Locate a closer drain or use a larger diameter drain line.
	❑ Simplex - Insufficient water supply for both service and backwash.	■ Schedule backwash for period of low usage. Adjust delta P switch, if applicable. Decrease volume setting on reset meter, if applicable.
	❑ Multiplex - Filter overrun.	■ Schedule backwash more frequently. Decrease volume setting on reset meter, if applicable.
	❑ Time between backwashes too long.	■ Solids loading has changed with time or loading.

LEAKS

Problem	Reason	Solution
Water leaks from any of the assembly levels	<input type="checkbox"/> Valve screws are not tightened.	<ul style="list-style-type: none"> ■ Depressurize the unit and tighten screws. <ul style="list-style-type: none"> • Main Valve Screws: 70 inch-pounds, • Level 5A screws: 50 inch-pounds, • Cap Screws: 50 inch-pounds.
	<input type="checkbox"/> One of the seals between assembly levels is pinched or missing.	<ul style="list-style-type: none"> ■ Replace the non-conforming seal.
	<input type="checkbox"/> One of the screw holes is stripped or cracked.	<ul style="list-style-type: none"> ■ Replace the level.
	<input type="checkbox"/> There is a crack on the seal area near a screw hole.	<ul style="list-style-type: none"> ■ Replace the level.

UNFILTERED WATER TO SERVICE

Problem	Reason	Solution
1. The by-pass is open	<input type="checkbox"/> An open by-pass allows for water to flow around the system without any treatment at all.	<ul style="list-style-type: none"> ■ Close the by-pass.
	<input type="checkbox"/> All simplex units incorporate an internal by-pass. While the unit is in backwash, this by-pass is open. Do not sample for quality while a simplex unit is in backwash.	<ul style="list-style-type: none"> ■ For a simplex system, sample during service, not backwash.
2. Raw water change	<input type="checkbox"/> Raw water analysis has changed.	<ul style="list-style-type: none"> ■ Retest raw water, and reprogram meter or timer as needed.
	<input type="checkbox"/> Raw water pressure low.	<ul style="list-style-type: none"> ■ See insufficient backwash.
3. Diffuser tube O-ring	<input type="checkbox"/> Diffuser tube O-ring rolled or cut.	<ul style="list-style-type: none"> ■ Replace O-ring.
4. Fouled media	<input type="checkbox"/> Obtain sample for analysis.	<ul style="list-style-type: none"> ■ Determine proper cleaning procedure.
5. Water feed pressure is too high (125 psi maximum)	<input type="checkbox"/> The pressure regulator is broken.	<ul style="list-style-type: none"> ■ Replace pressure regulator.

UNIT STICKS IN BACKWASH OR SERVICE CYCLE

Problem	Reason	Solution
1. Backwash	<input type="checkbox"/> The backwash flow path is plugged at the flow control.	<input type="checkbox"/> Clean the backwash flow path.
	<input type="checkbox"/> The regeneration drive pawl and/or spring is weak or broken.	<input type="checkbox"/> Replace the regeneration drive pawl.
	<input type="checkbox"/> There is a damaged tooth on the control disc.	<input type="checkbox"/> Replace the control disc.
	<input type="checkbox"/> The eccentric pinion is worn.	<input type="checkbox"/> Replace the eccentric pinion (snap fit).
	<input type="checkbox"/> On backwashing filters, low pressure or poor backwashing may cause a plugged bed.	<input type="checkbox"/> Increase inlet pressure or the frequency of backwash. Unit may need re-bedding.
	<input type="checkbox"/> Controller solenoid valve malfunctioning.	<input type="checkbox"/> Repair or replace solenoid.
2. Service	<input type="checkbox"/> Plugged controller solenoid valve.	<input type="checkbox"/> Repair or replace solenoid.
	<input type="checkbox"/> The control disc has a worn or missing tooth.	<input type="checkbox"/> Repair control disc.
	<input type="checkbox"/> Water meter not working.	<input type="checkbox"/> Repair or replace meter.
	<input type="checkbox"/> Controller not set properly.	<input type="checkbox"/> Review controller parameters.

WATER RUNNING TO DRAIN

Problem	Reason	Solution
1. The balance piston O-ring is not seated properly	<input type="checkbox"/> Water will leak past an improperly seated balance piston O-ring and out the drain.	<input type="checkbox"/> Depress the indicator several times to seat the O-ring. <input type="checkbox"/> Replace worn O-ring.
2. Bad control disc	<input type="checkbox"/> A scored control disc will allow a fast drip to a pencil sized stream to flow through the drain.	<input type="checkbox"/> Replace the control disc.
3. Valve not sealing, drain purge control, stem or piston quad rings not sealing	<input type="checkbox"/> Foreign matter under the seals will not allow them to seat properly.	<input type="checkbox"/> Disassemble and remove the foreign matter from seals.
	<input type="checkbox"/> Chlorine damage to seal.	<input type="checkbox"/> Replace valve.
	<input type="checkbox"/> Quad ring worn.	<input type="checkbox"/> Replace quad ring.
4. Low water pressure	<input type="checkbox"/> If the water pressure is less than 30 psi at the system outlet, it may not operate properly.	<input type="checkbox"/> Increase water pressure.

PARTS

TANKS, TANK FILL AND DISTRIBUTION

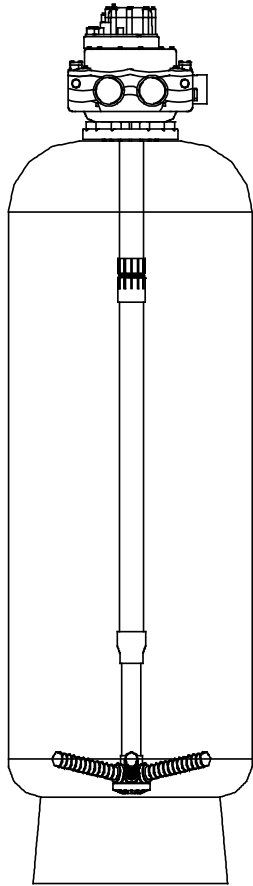

Complete Filter Tank Assemblies

Includes:

- Tank
- Diffuser
- Valve
- Resin
- Underbedding
- Manual
- Distributor

Macrolite	Simplex	Multiplex
18" x 65"	H12273	H12278
21" x 62"	H12274	H12279
24" x 65"	H12275	H12280
30" x 72"	H12276	H12281
36" x 72"	H12277	H12282
42" x 72"	H12332	H12333

Carbon

18" x 65"	H12263	H12268
21" x 62"	H12264	H12269
24" x 65"	H12265	H12270
30" x 72"	H12266	H12271
36" x 72"	H12267	H12272

Empty (used with calcite)

18" x 65"	H12283	H12288
21" x 62"	H12284	H12289
24" x 65"	H12285	H12290
30" x 72"	H12286	H12291
36" x 72"	H12287	H12292
42" x 72"	H12334	H12235

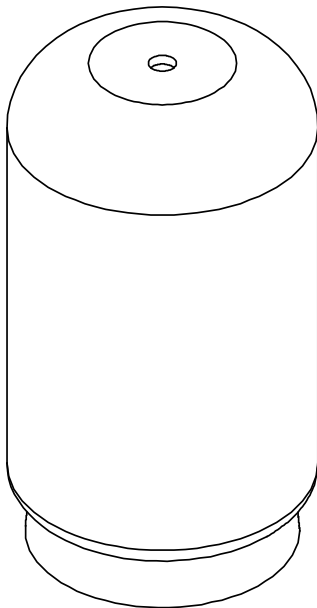

Tanks

18" x 65"	10999
21" x 62"	68015
24" x 65"	68016
30" x 72"	71047A
36" x 72"	68021
42" x 72"	68022

Distribution

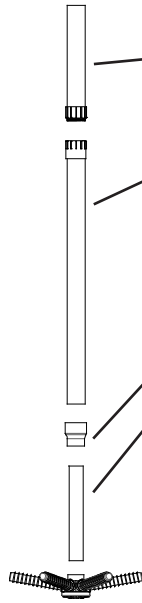

Riser Tube Kit (#12226)

Includes:

- Pipe, 1½" x 15"
- Pipe, 2" x 72" (requires cutting)
- Reducer Fitting, 1½" x 2"
- Adapter, 2" FNPT
- Adapter, 2" MNPT

Distributor Assembly

Includes:

- Hub, 1½" x Six lateral Sockets
- Six Laterals

18" x 65"	10996
21" x 62"	68363
24" x 65"	68363
30" x 72"	10997
36" x 72"	68364
42" x 72"	68364

Complete Valves

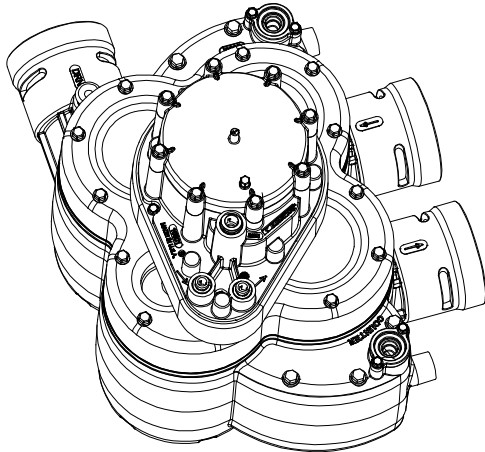

Complete Valves

Hydrus, Filter, Multi-tank.....	H12180
Hydrus, Filter, Simplex	H12184

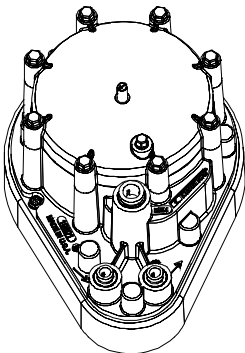

Level 1/2 Assembly

Hydrus, Filter, Multi-tank.....	12175
Hydrus, Filter, Simplex	12181

Level 1 / 2

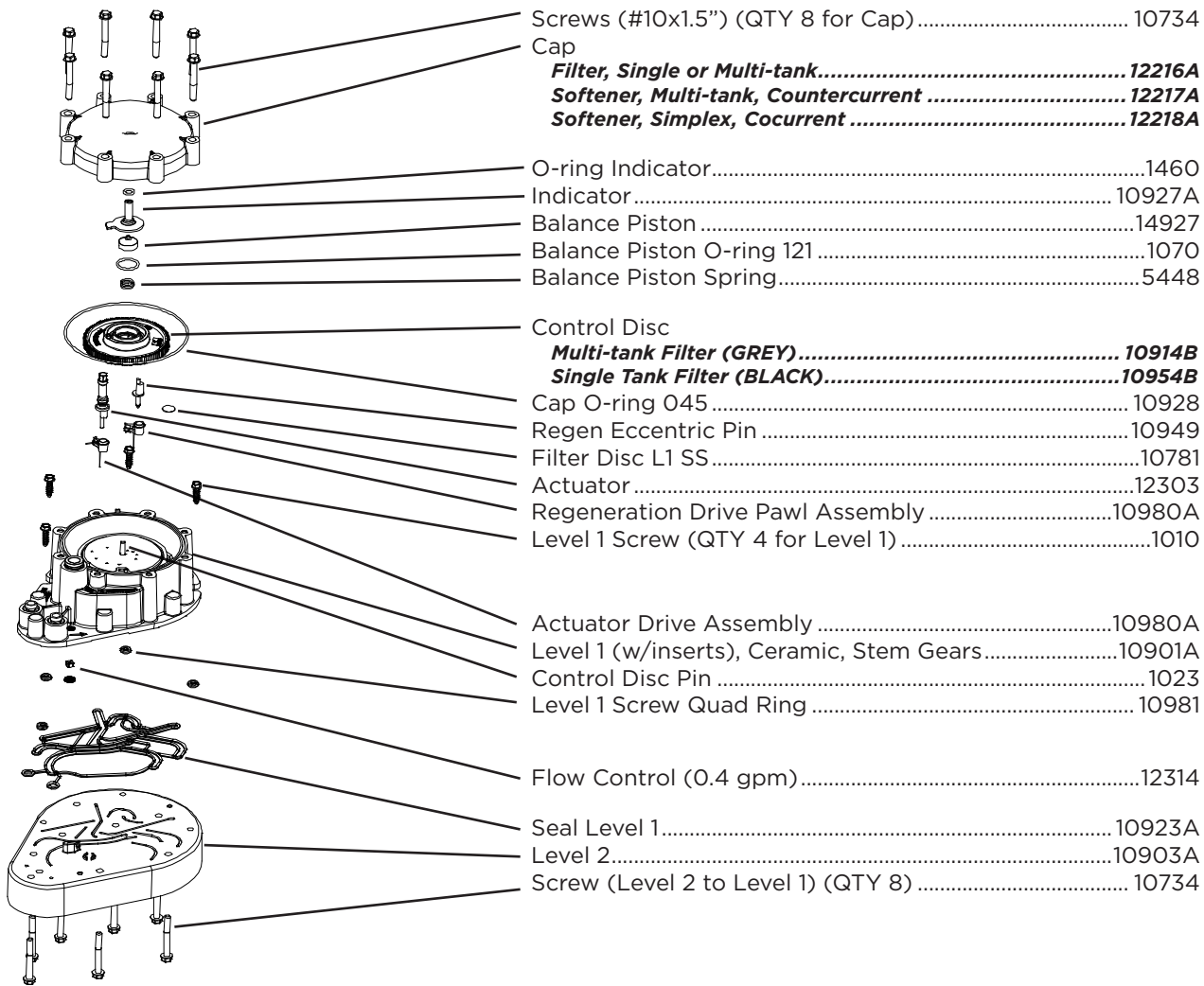

Level 3 - 5A

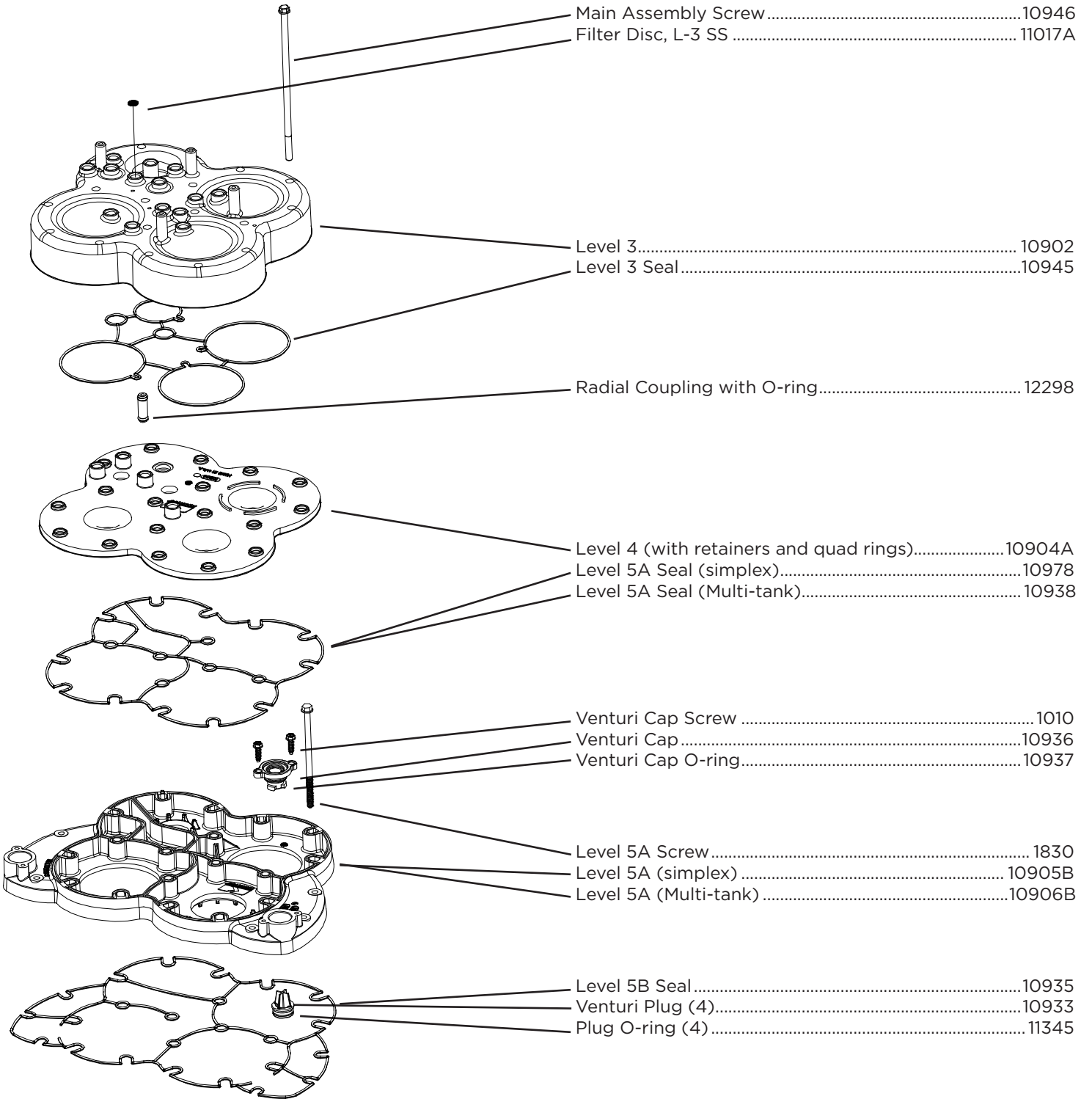

Level 5B - Base

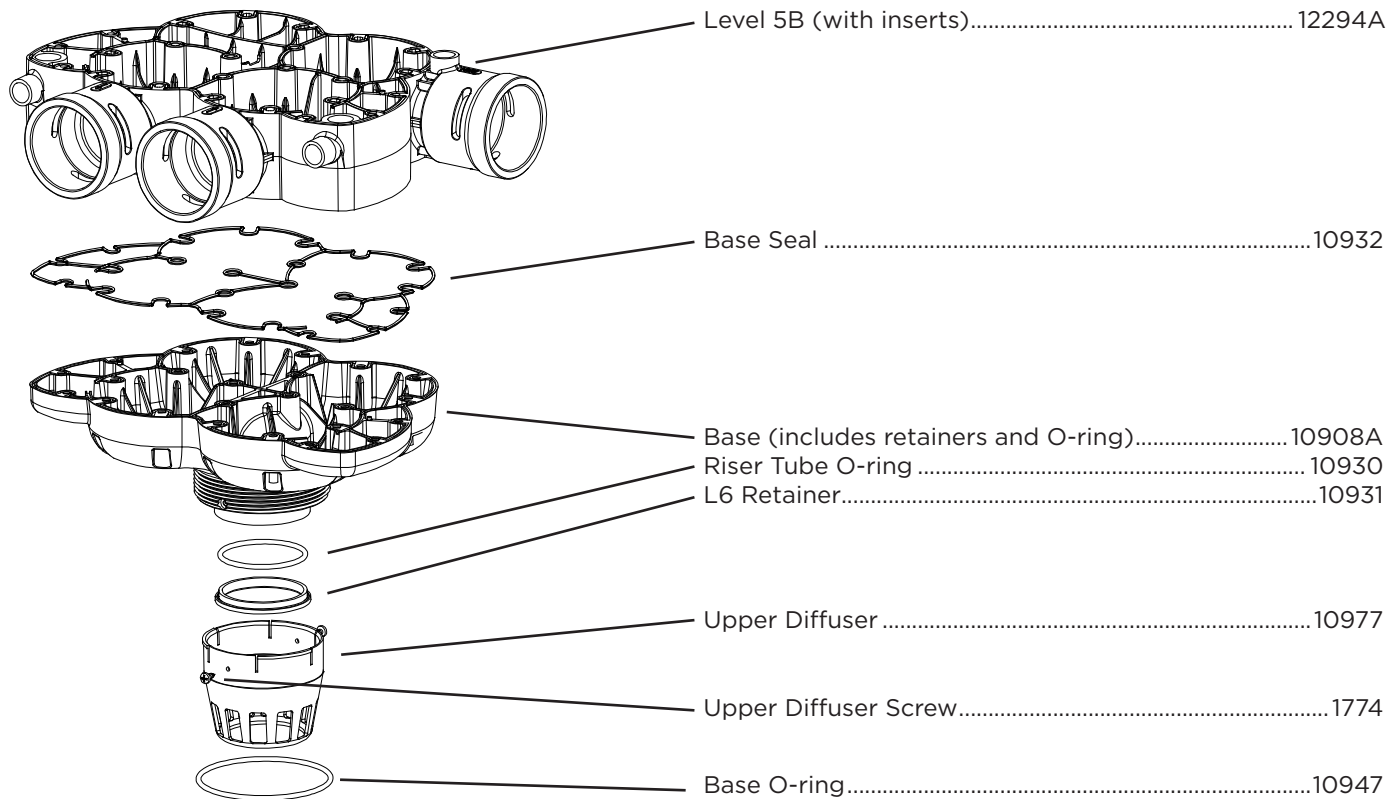

Gearing

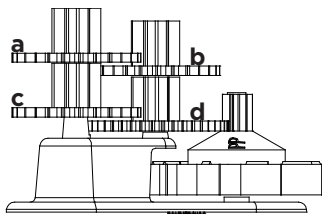

Unit (time).....Short hand (a-b-c-d)
Standard Filter (20 min) 2-2-2-2-#10 Jet
Special Filter (40 min) 2-2-2-3-#8 Jet
Special Softener (90 min) 2-1-5-4-#8 Jet

Gearing Retainer Clip..... 10985A

Turbines

#8 9272A
 #8 Jet..... 11011A
 #10 Jet 8781F

Inlet / Outlet Adapters

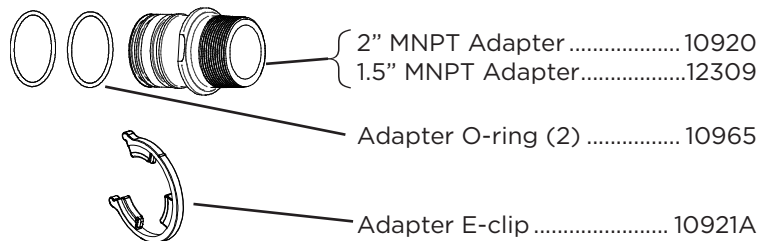

Gears

Gears	
1 1522
2 1523
3 1524
4 1525
5 1526
6 1527
7 1528
P7 7890A

Miscellaneous

2cc Lube Packet (**MED 420**).....11319
 Hydrus System Service Kit.....12316
 Technical Manual.....12224H
 Product Label, White Label.....10410

Drain Flow Control

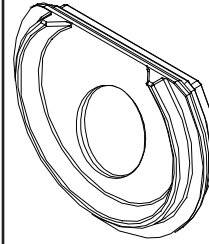

Backwash Flow Control (universal).....10919
 O-ring (BWFC).....10967

Internal Valves



Control Valve and Start Next Valve

Valve Piston (with quad ring)..... 7872A
 Seal 8193A



Purge Valve

Piston (with quad ring)..... 17398
 Seat (with glued seal)..... 10984A

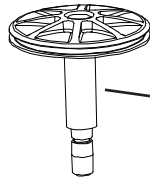
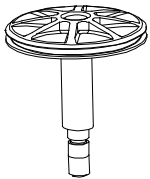

Inlet/Outlet/Drain Valve

Piston (with quad ring).....10943
 Valve Extension..... 12305
 Seat (with over molded seal)..... 10942A
 Piston O-ring, 011.....10634
 Piston Spring..... 10964
 Piston Washer..... 10971

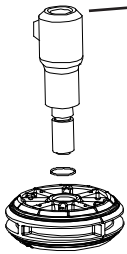

Piston Screw.....10734
 Piston Screw (long).....12306



Base Smart Start Controller

Complete Base Smart Start Controller

Base Smart Start Controller, No Box.....12137

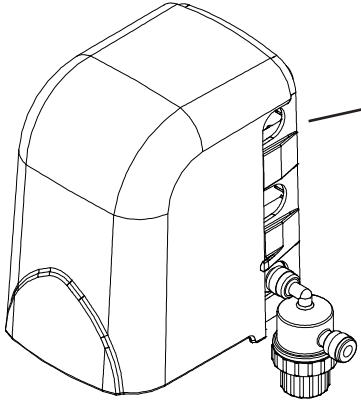

Enclosure

Back Mounting Plate Enclosure12100

Midwall Enclosure.....12101

Front Cover Enclosure.....12102

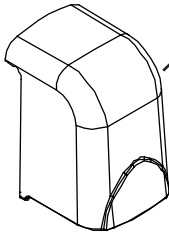
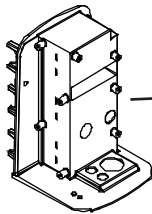
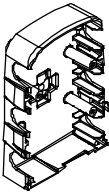

Electrical

Timer Circuit with Coating (SS Base).....12142

Two-Terminal Battery Pack.....12106

Bi-Stable Solenoid, including fittings17309

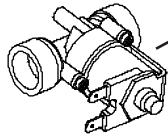
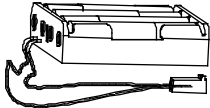
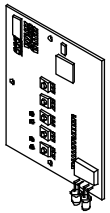

Miscellaneous

External Power Supply, US Version12128

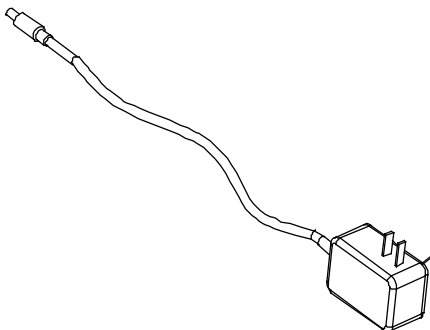

Meters - Remote Reset (Smart Start Base)

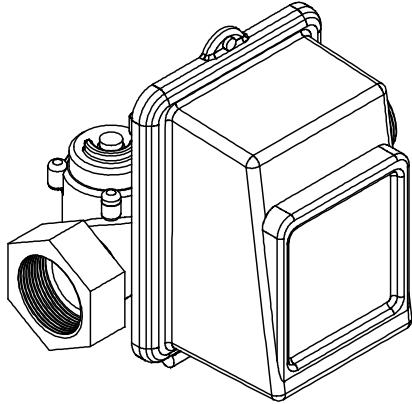

Immediate Backwash, 120 VAC

2" Meter, REM, PL, 120V 50/60HZ, 3 - 150 gpm, GAL Range - 6,250 - 106,250	16714
3" Meter, SS REM, 120V 50/60HZ, STD, 7 - 300 gpm, GAL Range - 3,750 - 63,750	16712
3" Meter, REM, 120V 50/60HZ, EXT, 7 - 300 gpm, GAL Range - 18,750 - 318,750	16713

Elite+ Smart Start Controller

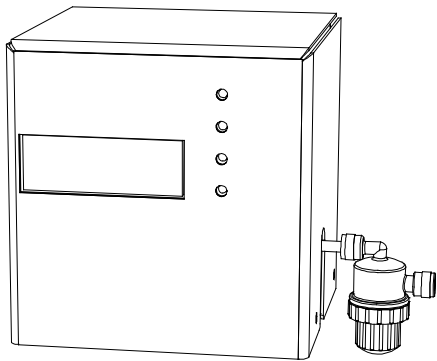

Complete Elite+ Smart Start Controller	16945
--	-------

Meters - Remote Reset (Elite+ Smart Start)

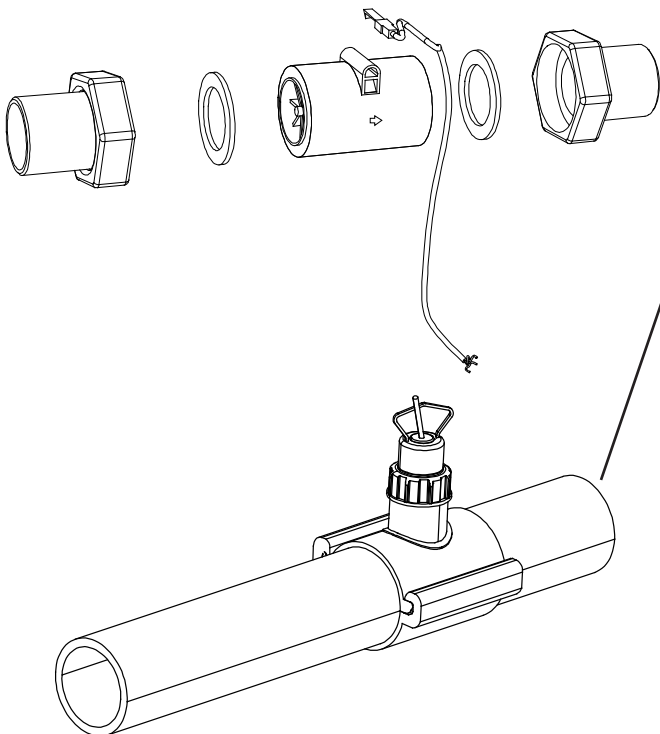

Flow Meter, 2"	16946
Flow Meter, 3"	16947

Pressure Differential Switch, PN 16948

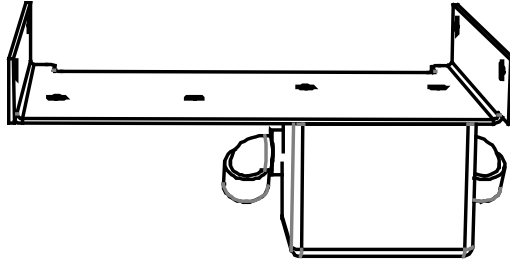

Inline Filter, 1/4" Tube, PN 12144

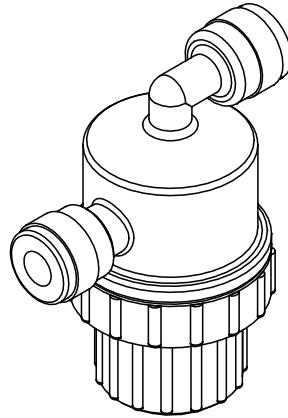

Miscellaneous Components

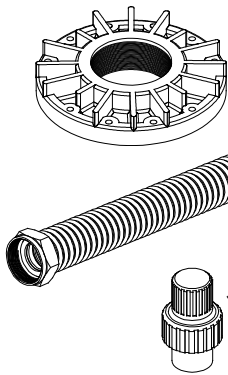

Adapter Flange, 6" to 4" (required on 36" and 42" tanks) ..	72868
2" Flex Hose Connector.....	13096
Vacuum Breaker 1"	58547

Garnet Gravel.....	64143
1/4" X 1/8" Gravel.....	1226A
Flint Gravel.....	57580

Media

Macrolite RX Media, ft ³	16019
Carbon Media, ft ³	57728
Calcite Media, ft ³	6773

Installation Kit

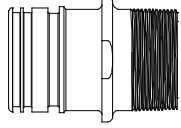
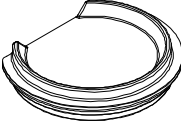
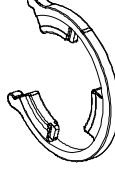
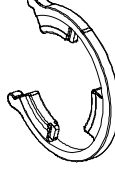
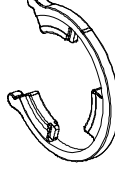
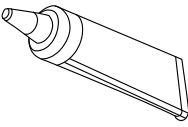
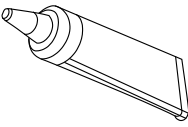
Installation Kit, 12179B		Quantity
Includes:		
	2" MNPT Adapters (PN 10920).....	3
	O-ring, 028 (PN 10967).....	1
	Flow Control, Undrilled (PN 10919).....	1
	E-clips (PN 10921A).....	3
	O-rings, 228 (PN 10965).....	6
	Silicone Packets, 2.00mL (PN 1452).....	3
	Diffuser Screws (PN 1774).....	2



OWNER'S MANUAL

HYDRUS COMMERCIAL FILTRATION SYSTEMS

©2021, Kinetico Incorporated

Corporate Headquarters
10845 Kinsman Road
Newbury, Ohio 44065

www.KineticoPRO.com

Product No. 10484

Rev. 06.03.2021